



FLEXY GRILL SEH103E

Ultra-rapid
Salamandra

CONSTRUCTION FEATURES

- Stainless steel construction
- Adjustable upper plate to have the heating surface closer to the food
- Ultra rapid and high-performance heating elements
- Lower cooking plate made of glass ceramics
- Safety thermostat to avoid overheating

FUNCTIONAL FEATURES

- Electronic controls with digital display protected by a polycarbonate panel
- Possibility of selecting the cooking zone, activating 1 or 3 heating elements
- Encoder to adjust cooking time up to 20'
- Warm holding function after the cooking cycle has finished, to be set during programming separately
- Plate detection system for automatic switching on or off
- (3) heating elements housed in a special ceramic dish
- Possibility of selecting the heating level of the lower cooking plate (4 levels)

OPTIONS & ACCESSORIES

- Trays
- Adjustable feet
- Stand with side racks GN1/1

MODULINESRL

Via dell'Industria 11, Z.I. San Giacomo di Veglia 31029 Vittorio Veneto (TV) - ITALY
 tel. +39 0438 5063 - fax +39 0438 912 323 - info@moduline.it - www.moduline.it



moduline

TECHNICAL INSTALLATION DIAGRAM

Electricity supply
cable inlet

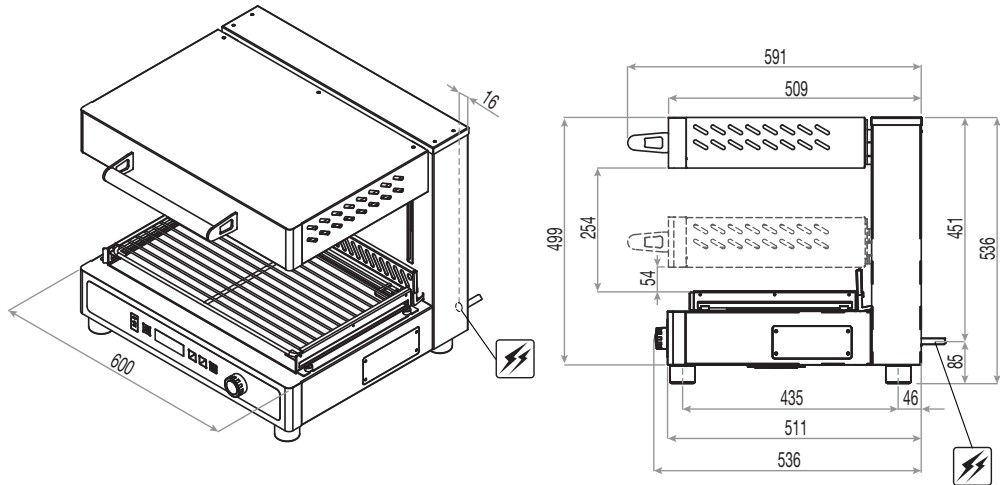

Overall dimensions
(W x D x H) - mm

600 x 593 x 538h

Cooking plate

1 GN 1/1

Upper heating
plate [mm]

490 x 260
(3 heating elements)

Lower heating
plate [mm]

530 x 330 (one plate)

Net weight
[Kg]

59,2

Power supply

380-415V 3N 50/60Hz

Total input
[kW]

7,1 (400V)

Amps.
[A]

13,1 (400V)

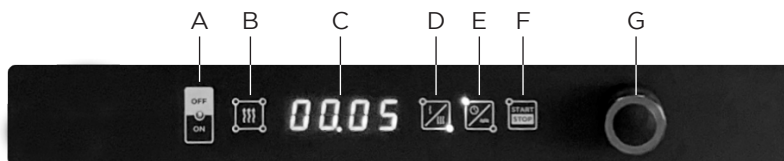

- A ON/OFF switch
- B Selection of heating level of the lower plate
- C Display
- D Selection of upper heating elements
- E Cooking / Warm holding
- F START/STOP button
- G Knob

MODULINESRL

Via dell'Industria 11, Z.I. San Giacomo di Veglia 31029 Vittorio Veneto (TV) - ITALY
tel. +39 0438 5063 - fax +39 0438 912 323 - info@moduline.it - www.moduline.it