

TECHNICAL FEATURES

External structure	Heating surface in high-performance composite material (food-grade stainless steel compliant with standard NFA36-711).
Dimensions	800x800mm
Cooking surface	634x634mm
Power	16000W (4x4000W)
Control panel	Controlled by a 360° knob and temperature display in °C on a 4 digit display.
Amperage	24A per phases
Functions	Temperature setting: min: 60°C - max: 250°C. Temperature adjustment range: 10°C Time to reach 200°C: less than 3 minutes.
Power supply	380V Three-phase 50-60Hz (3 phases + neutral + ground) Compatible with TERRA WATT and SICOTRONIC energy optimisers
Weight	90kg
Standards	Complies with European standards for safety of electrical appliances
Composition of the kit	<ul style="list-style-type: none"> - 1 Cooking unit fitted with a connectable drain tube for cooking juices - 2 Compact duo remote generators - 1 Integration framework - 2 encastrable controls unit - 1 Tangential cooling turbine - Connecting cables 1m50 - Adhesion promoter & food-grade silicone cartridge (Novasil) - Spatula supplied. <p>(Custom connection cables available in 3, 5, 8, 10, 12 or 15m lengths)</p>
Details	Supplied without mains connection cable Designed and manufactured in France

P4iM: Three-phase 4 zone induction griddle kit Remote generators



Knobs control version with displays (to be built-in on the customer structure)



ADVENTYS
Route de Pagny - 21250 Seurre - France
www.adventys.com
contact@adventys.com
T: 03.80.20.46.15

Importante Note
Adventys reserves the right to change specifications without notice.

Cooking block dimensions 800 x 800 mm

Cut-out dimensions for integration: 810mm x 810mm

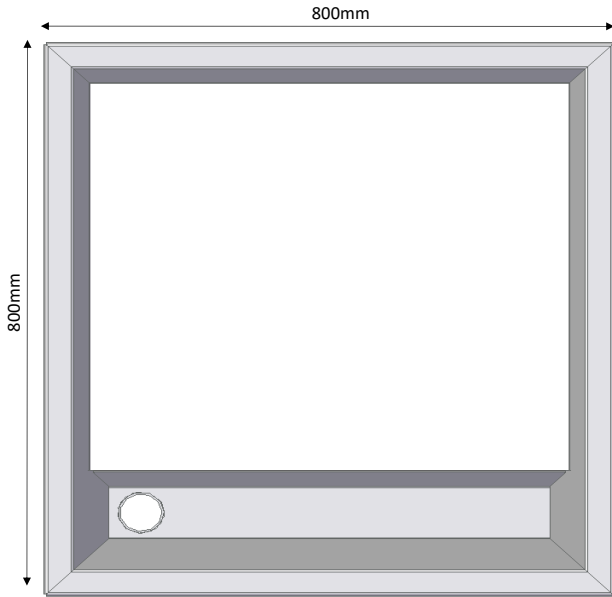

Application of a 5mm gasket (silicone cartridge provided) around the cooking block necessary to ensure the tightness of your appliance

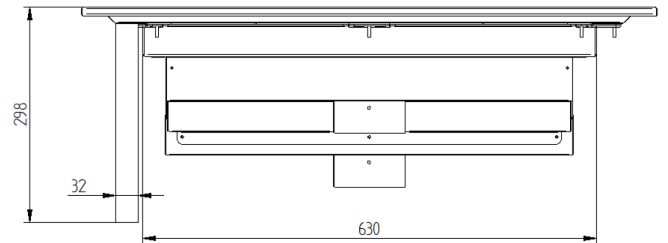
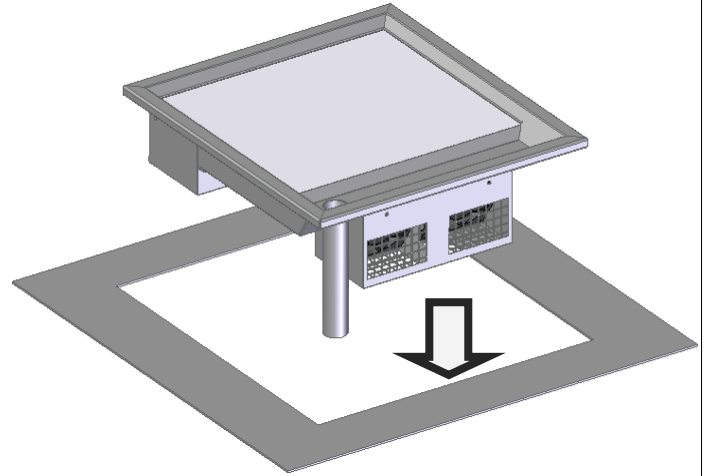

Cooling

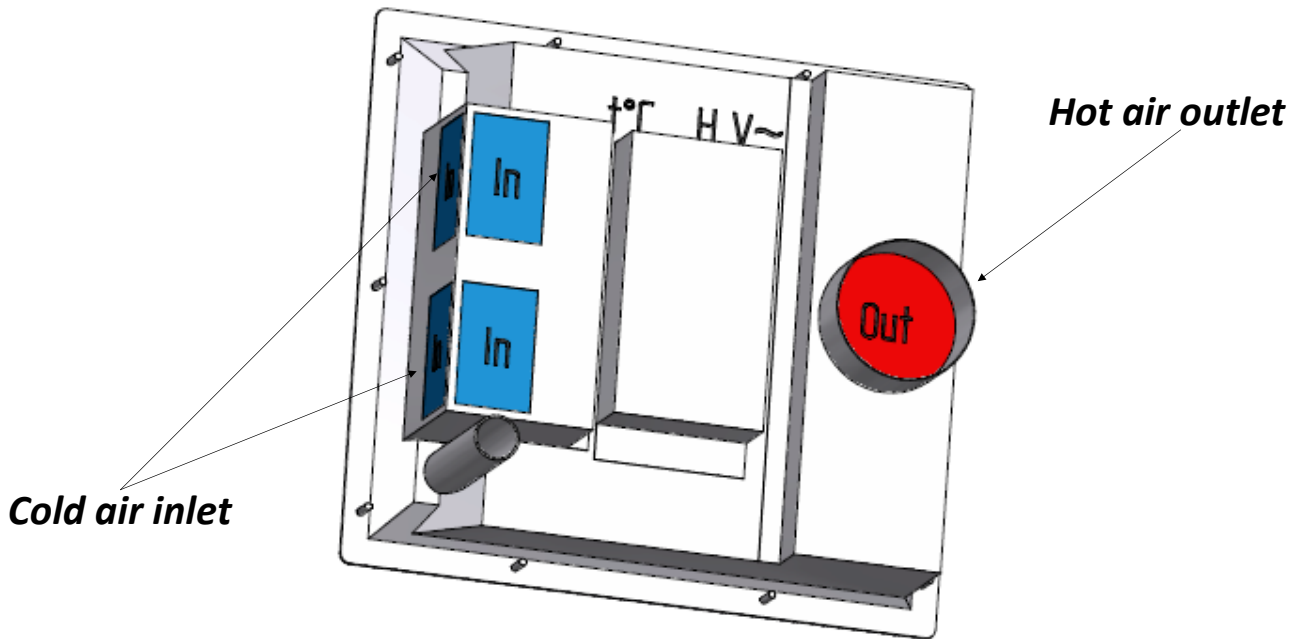

ADVENTYS
 Route de Pagny - 21250 Seurre - France
 www.adventys.com
 contact@adventys.com
 T: 03.80.20.46.15

Importante Note
 Adventys reserves the right to change specifications without notice.

Stainless steel frame for cooking unit integration

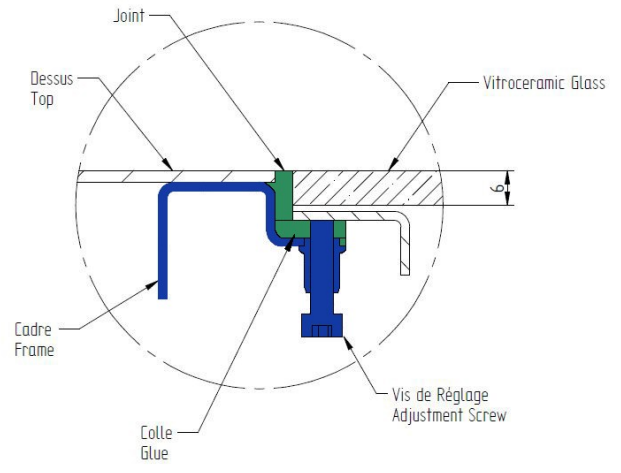

Worktop cut-out dimensions for plancha integration: 810mm x 810mm

Knob control panel + display

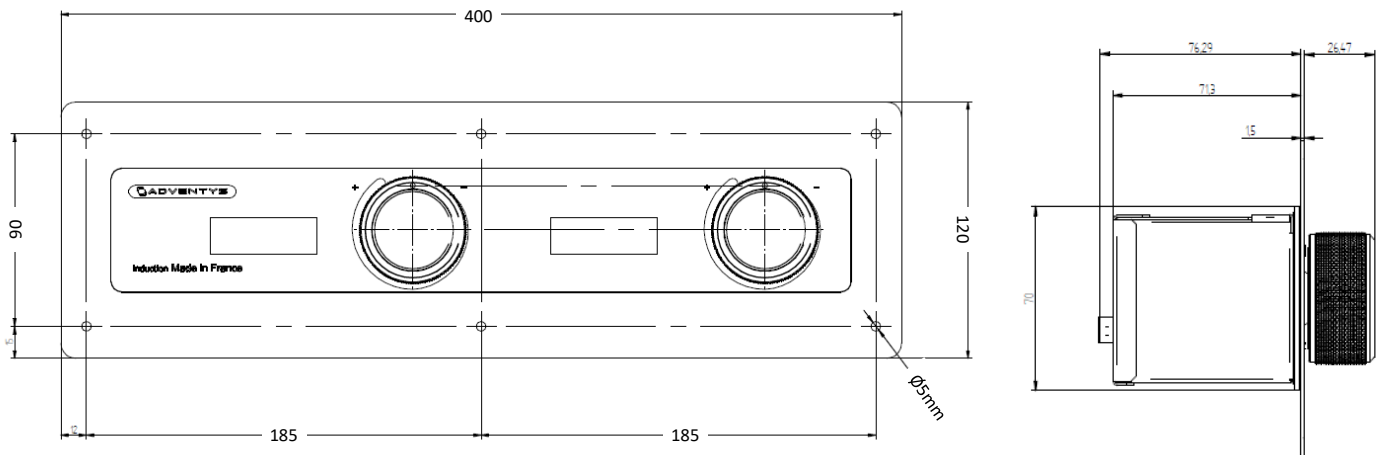

Cut-out dimensions for built-in control: 367 x 72 mm + 6 trous R5mm

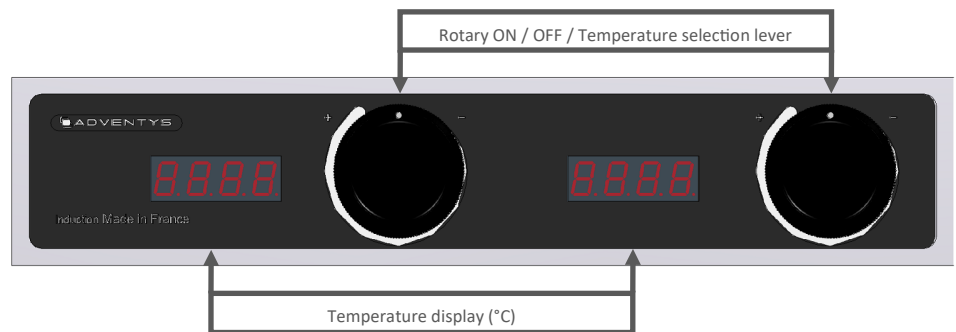

ADVENTYS
 Route de Pagny - 21250 Seurre - France
 www.adventys.com
 contact@adventys.com
 T: 03.80.20.46.15

Importante Note
 Adventys reserves the right to change specifications without notice.

Compact duo remote generator

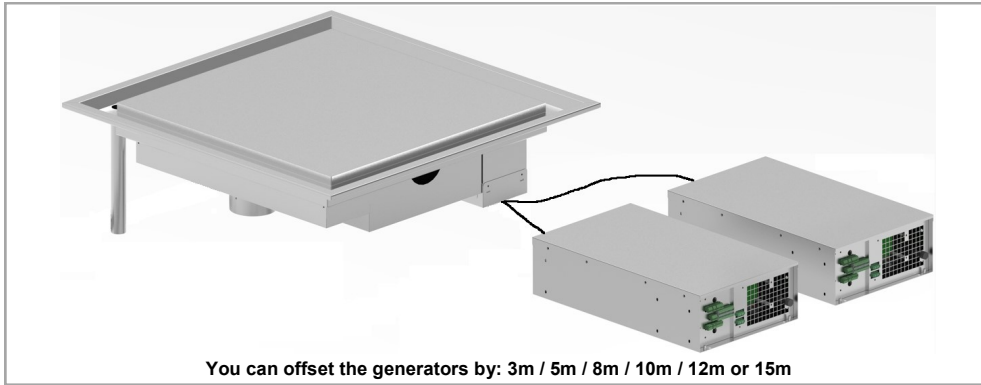

You can offset the generators by: 3m / 5m / 8m / 10m / 12m or 15m

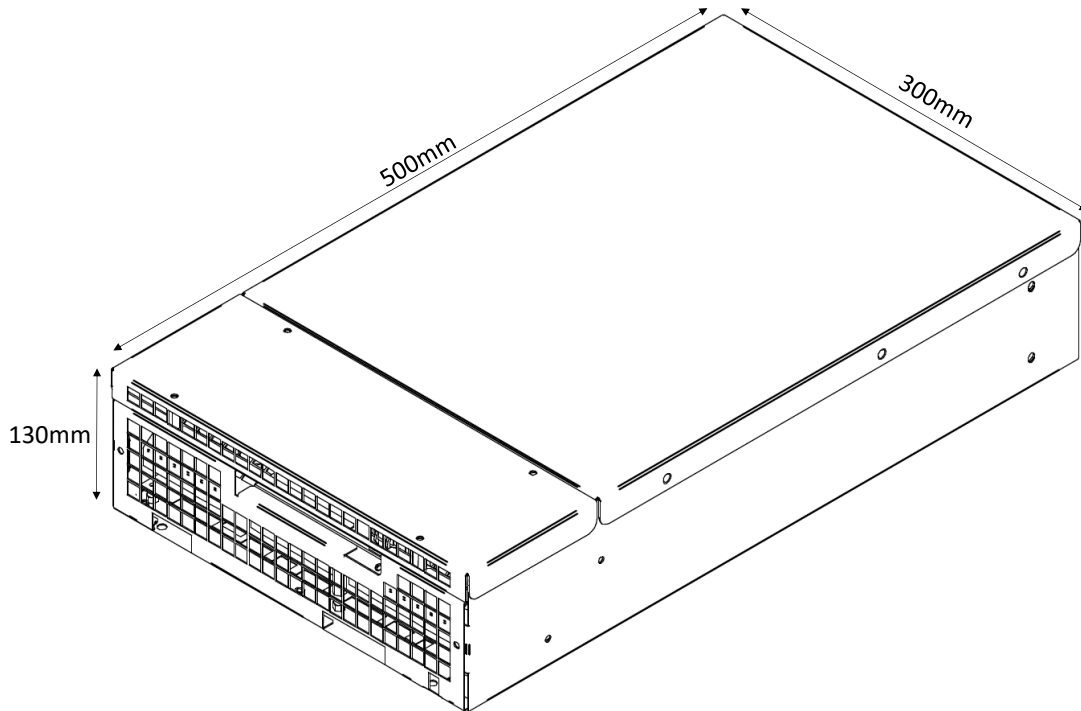

FRONT

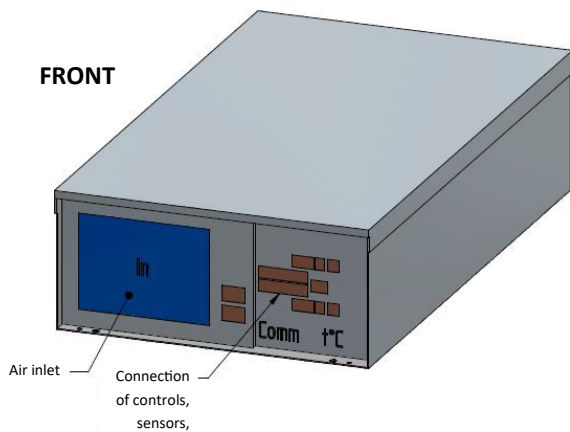

REAR

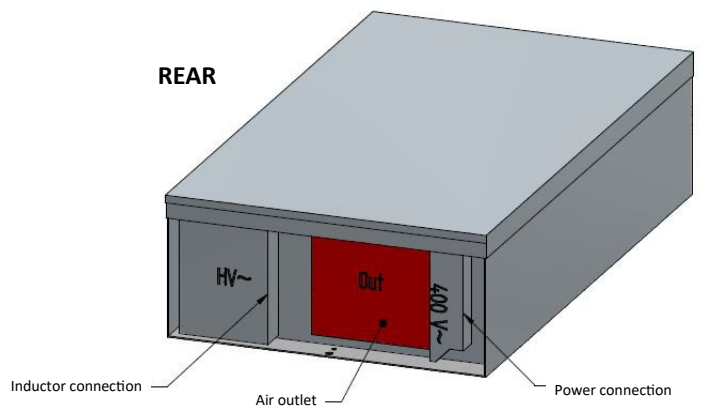

ADVENTYS
 Route de Pagny - 21250 Seurre - France
www.adventys.com
contact@adventys.com
 T: 03.80.20.46.15

Importante Note
 Adventys reserves the right to change specifications without notice.

Tangential turbine

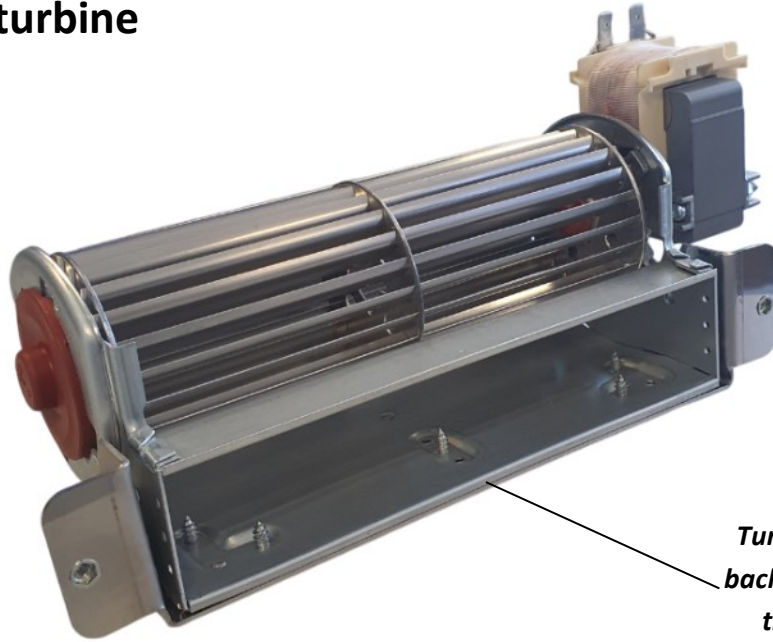

Turbine to be attached, at the back of your structure to ensure the cooling of your device

Cooling

Generator installation with tangential

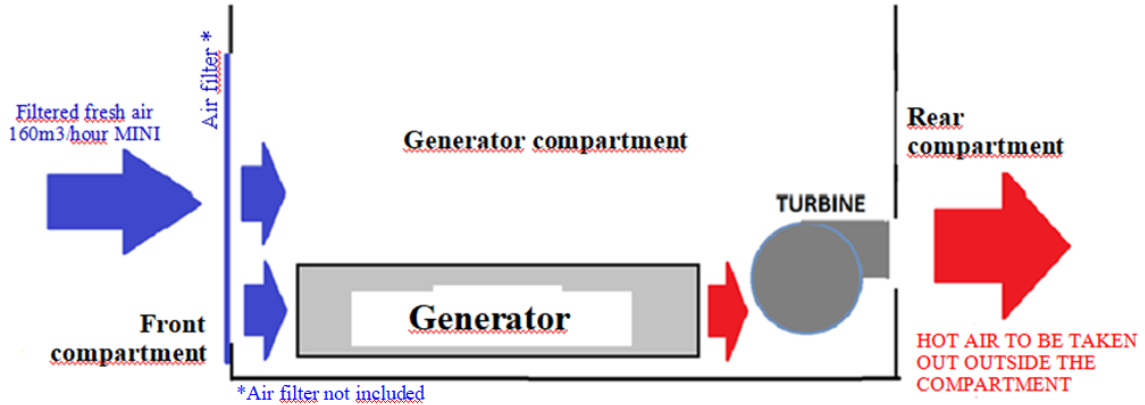

Turbine Integration

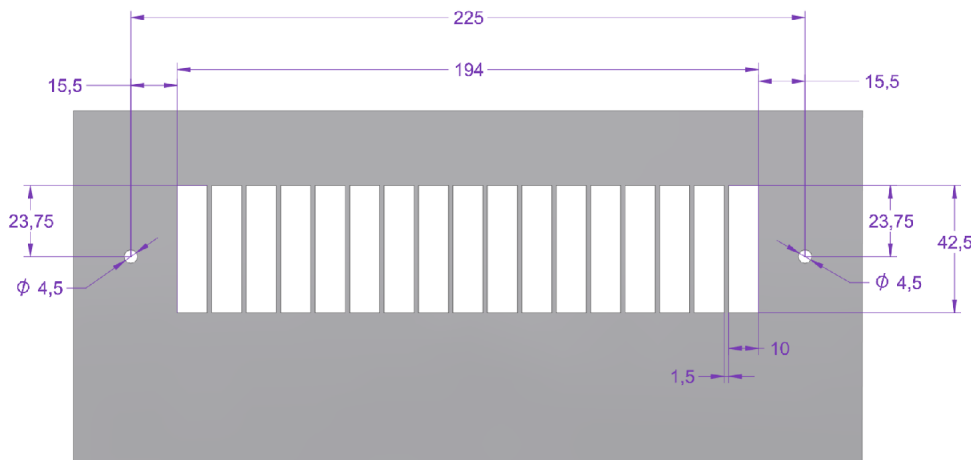

Tangential turbine integration plan (at the back of the customer structure)

ADVENTYS
 Route de Pagny - 21250 Seurre - France
 www.adventys.com
 contact@adventys.com
 T: 03.80.20.46.15

Importante Note
 Adventys reserves the right to change specifications without notice.

