

ELECTRIC BRATT PAN MANUAL TILTING 43 LT - STAINLESS STEEL TANK

Project:
Rev.:
Zone:
Location:



CODE
CR1014719

MODEL
Q70BR/E80

SERIE
QUEEN 7

GENERAL FEATURES

- 15/10 worktop thickness
- Stainless steel, Scotch-Brite finish
- Sturdy and powerful with compact design
- Depth of 700 mm means it will fit the most common configurations
- Catalogue offers more than 300 standard models
- Worktop, base cabinet, base cabinet with doors and oven versions
- Twin-piece knobs prevent the infiltration of dirt and are watertight
- Gas ranges having burners with various configurations and power ratings: 3,5 kW - 5,7 kW e 7 kW
- Wide range of accessories

The front bar is a new design feature that increases the kitchen's visual importance and offers clear benefits: it is a comfortable place for the chef to lean on; it means you will remain at a safe distance from the worktop and therefore protects from accidentally knocking against both items lying on the worktop and the knobs.



TECHNICAL DETAILS

ELECTRIC
ELECTRIC BRATT PAN MANUAL TILTING 43 LT - STAINLESS
STEEL TANK

- Manual water fill.
- Self-balanced lid with double steel wall.
- Safety device interrupting power supply when tub is lifted.
- Adjustable temperature from 100 to 280°C.
- Heating element unit made of incoloy stainless steel heating elements.
- Safety thermostat.

ELECTRIC BRATT PAN MANUAL TILTING 43 LT - STAINLESS STEEL TANK

CODE
CR1014719

MODEL
Q70BR/E80

SERIE
QUEEN 7

TECHNICAL INFORMATION

SPECIFICATIONS	DATA
CODE	CR1014719
DEFINITION	Q70BR/E80 BRASIERA EL.M80 43LT INOX
COMMERCIAL LINE	QUEEN
SUPPLY	ELETTRICA
WIDTH	800 MM
DEPTH	700 MM
HEIGHT	870 MM
NET WEIGHT	123,000
VOLUME	0,487 M3
PACKAGING LENGTH	850,000
PACKAGING WIDTH	850,000
PACKAGING HEIGHT	1150,000
PACKAGING VOLUME	0,831
PACKAGING GROSS WEIGHT	136,000
POWER SUPPLY VOLTAGE STANDARD	380-415V 3N
FREQUENCY	50-60 Hz
ELECTRIC POWER	9,900 KW
IPX PROTECTION	IPX4
CERTIFIED MODEL	Q70BR/E80
CERTIFICATION NUMBER	-

ELECTRIC BRATT PAN MANUAL TILTING 43 LT - STAINLESS STEEL TANK

CODE
CR1014719

MODEL
Q70BR/E80

SERIE
QUEEN 7

ACCESSORIESES

CODE	MODEL	DESCRIPTION
CR0592770	ZA40	FRONT PLINTH
CR0982789	ZL90	SIDE PLINTH SERIE 900
MA97432000	NXR	SET OF WHEELS NXR
MA97433000	NXRI	SET OF WHEELS INOX NXRI
CR1015369	QCH20	DIRECTABLE WATER FLUE
CR0592869	CR0592869	4 PIEDI X INSTALL.SU ZOCCOLO DI CEMENTO
CR1015339	QPT	N. 4 PIEDINI IN ACCIAIO INOX PER INSTALLAZIONE SU PIANI
CR0592879	CR0592879	KIT ANTI RIBALTAMENTO 2 PIEDI X N900
CR0592399	NXTVT1	KIT PANNELLI X BASE TECN.1 FRONTE NXTVT1
CR0592409	NXTVT2	KIT PANNELLI X BASE TECN.2 FRONTI NXTVT2
CR1018879	Q90FTDX	FIANCO TERMINALE DESTRO QUEEN
CR1018889	Q90FTSX	FIANCO TERMINALE SINISTRO QUEEN
CR0980009	CANT	TUBULAR HANDRAIL FRONTALE (AL METRO LINEARE)
CR0980019	9CLAT	TUBULAR HANDRAIL LATERALE SERIE 900
BN418031900211	9PRD	PIANO LATERALE RIBALTABILE DESTRO
BN418031900460	9PFD	PIANO LATERALE FISSO DESTRO
BN418031900221	9PRS	PIANO LATERALE RIBALTABILE SINISTRO
BN418031900470	9PFS	PIANO LATERALE FISSO SINISTRO
BN418031900121	9KR	KIT STATIC WARMER

**ELECTRIC BRATT PAN MANUAL TILTING 43
LT - STAINLESS STEEL TANK**

CODE
CR1014719

MODEL
Q70BR/E80

SERIE
QUEEN 7

QUEEN

**PRODUCT'S
RANGE PLUS**

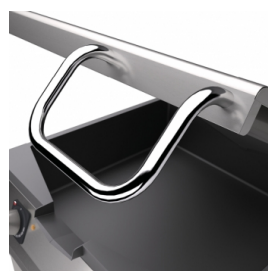

Self-balancing lids.

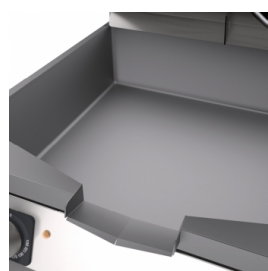

Wide-radius tilting cooking tank.

Equipment certified for low voltage
directive 2014/35 / EU according to
the international CB scheme.



Manual water filling



Thanks to the water jet ingress
protection rating, awarded after
passing specific tests, knobs and
knob bezels can be washed at the
end of the working day without
affecting performance or safety.



The front bar is a comfortable place
for the chef to lean on; it means you
will remain at a safe distance from
the worktop and therefore protects
from accidentally knocking against
both items lying on the worktop
and the knobs.

ELECTRIC BRATT PAN MANUAL TILTING 43 LT - STAINLESS STEEL TANK

CODE
CR1014719

MODEL
Q70BR/E80

SERIE
QUEEN 7

SCHEMA DI INSTALLAZIONE - INSTALLATION DIAGRAM - INSTALLATIONSPLAN - SCHÉMA D'INSTALLATION -
ESQUEMA DE INSTALACION -INSTALLATIESCHEMA - IINSTALLATIONSRTNINGAR

MISURE IN mm - DIMENSIONS IN mm - ABMESSUNGEN IN mm
MESURES EN mm - MEDIDAS EN mm - MATEN IN mm

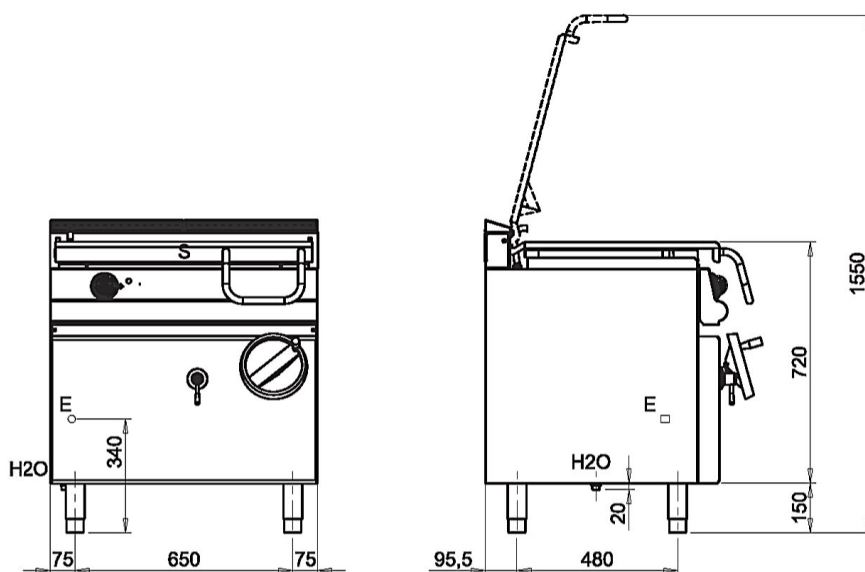

70BR/E8_

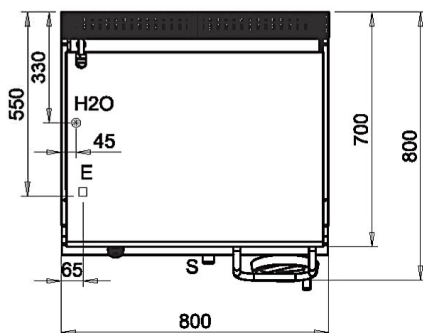

Legenda - Legende - Key - Légende - Leyenda - Legenda

- E** Pressacavo entrata linea elettrica - Stopfbuchse - Electric cable stress relief
Presse étoupe de cable él. - Pisacable - Elektrische kabelwartel
- H2O** Attacco arrivo acqua - Wasseranschluss - Water inlet
Arrivée eau - Union de agua - Wateraansluiting
EN ISO 228-1 G 3/4
- S** Scarico vasca - Wannenabflussrohr - Pan outlet
Vidange du bac - Descarga cuba - Water toevoer