

ELECTRIC BOILING PAN - INDIRECT HEATING 100 LT -

Project:
Rev.:
Zone:
Location:



CODE
CR1018099

MODEL
Q90PF/ED100

SERIE
QUEEN 9

GENERAL FEATURES

- AISI 304 stainless-steel bases and worktops, Scotch-Brite finish
- Depth of 900 mm for high power and performance
- Catalogue offers more than 350 standard models
- Worktop, base cabinet, base cabinet with doors and oven versions
- 20/10 worktop thickness
- Twin-piece knobs prevent infiltration of dirt and have an IPX5 water ingress protection rating
- Gas ranges having burners with various configurations and power ratings: 3.5 kW - 5.7 kW, 7 kW and 10 kW. Double-ring burners for 7 and 10 kW models
- Wide range of accessories

The knobs offer optimum grip and help the chef to have the setting controls right under his eyes. Special attention has also been paid to the knob bezel that has been expertly designed to avoid penetration of liquids and/or dirt. Thanks to the IPX5 water jet ingress protection rating, awarded after passing specific tests, knobs and knob bezels can be washed at the end of the working day without affecting performance or safety.



TECHNICAL DETAILS

ELECTRIC
DIRECT HEATING
ELECTRIC BOILING PAN - INDIRECT HEATING 100 LT

- Water filled via two solenoid valves;
- Water drained with 2" valve
- AISI 316 stainless steel container bottom
- No water in the interspace indicator light;
- Safety thermostat to interrupt heating until restore of sufficient water level;
- 3 steel heating elements outside the container bottom, or 2 armoured heating element units inside the interspace.

ELECTRIC BOILING PAN - INDIRECT HEATING 100 LT -

CODE CR1018099	MODEL Q90PF/ED100	SERIE QUEEN 9
-------------------	----------------------	------------------

TECHNICAL INFORMATION

SPECIFICATIONS	DATA
CODE	CR1018099
DEFINITION	Q90PF/ED100 PENTOLA EL.M80 DIR.100 LT
COMMERCIAL LINE	QUEEN
SUPPLY	ELETTRICA
WIDTH	800 MM
DEPTH	900 MM
HEIGHT	870 MM
NET WEIGHT	129,800
VOLUME	0,626 M3
PACKAGING LENGTH	860,000
PACKAGING WIDTH	1020,000
PACKAGING HEIGHT	1300,000
PACKAGING VOLUME	1,140
PACKAGING GROSS WEIGHT	145,000
POWER SUPPLY VOLTAGE STANDARD	380-415V 3N
FREQUENCY	50-60 Hz
ELECTRIC POWER	12,000 KW
IPX PROTECTION	IPX5
CERTIFIED MODEL	Q90PF/ED100
CERTIFICATION NUMBER	-

ELECTRIC BOILING PAN - INDIRECT HEATING 100 LT -

CODE CR1018099	MODEL Q90PF/ED100	SERIE QUEEN 9
-------------------	----------------------	------------------

ACCESSORIESES

CODE	MODEL	DESCRIPTION
MA97347000	XP9-C5	BOILING PAN BASKET 50LT XP9-C5
MA97348000	XP9-CV5	BOILING PAN BASKET 50LT XP9-CV5
CR0599730	7C8	BASKET FOR PASTA 1 SECTION FOR BOILING PAN - 80 Lt. HOLE Ø 3 MM
CR0599740	7CV8	BASKET FOR VEGETABLE 80LT XP7CV8
MA97349000	XP9-I5	DRAIN FUNNEL X 50LT XP9-I5
CR0592790	ZA80	FRONT PLINTH
CR0982789	ZL90	SIDE PLINTH SERIE 900
MA97432000	NXR	SET OF WHEELS NXR
CR0592869	CR0592869	4 PIEDI X INSTALL.SU ZOCCOLO DI CEMENTO
CR1015339	QPT	N. 4 PIEDINI IN ACCIAIO INOX PER INSTALLAZIONE SU PIANI
CR0592879	CR0592879	KIT ANTI RIBALTAMENTO 2 PIEDI X N900
CR0592399	NXTVT1	KIT PANNELLI X BASE TECN.1 FRONTE NXTVT1
CR0592409	NXTVT2	KIT PANNELLI X BASE TECN.2 FRONTI NXTVT2
CR1018879	Q90FTDX	FIANCO TERMINALE DESTRO QUEEN
CR1018889	Q90FTSX	FIANCO TERMINALE SINISTRO QUEEN
CR0980019	9CLAT	TUBULAR HANDRAIL LATERALE SERIE 900
BN418031900211	9PRD	PIANO LATERALE RIBALTABILE DESTRO
BN418031900460	9PFD	PIANO LATERALE FISSO DESTRO
BN418031900221	9PRS	PIANO LATERALE RIBALTABILE SINISTRO
BN418031900470	9PFS	PIANO LATERALE FISSO SINISTRO

ELECTRIC BOILING PAN - INDIRECT HEATING 100 LT -

CODE
CR1018099

MODEL
Q90PF/ED100

SERIE
QUEEN 9

PRODUCT'S RANGE PLUS



Indirect heating with low-pressure steam generated by the water in the jacket: safe and easy operation thanks to pressure gauge, safety valve and compensating valve.



Stainless-steel pan with AISI316 bottom

Equipment certified for low voltage directive 2014/35 / EU according to the international CB scheme.



May be filled with either hot or cold water.



Thanks to the IPX5 water jet ingress protection rating, awarded after passing specific tests, knobs and knob bezels can be washed at the end of the working day without affecting performance or safety.



The front bar is a comfortable place for the chef to lean on; it means you will remain at a safe distance from the worktop and therefore protects from accidentally knocking against both items lying on the worktop and the knobs.

ELECTRIC BOILING PAN - INDIRECT HEATING 100 LT -

CODE
CR1018099

MODEL
Q90PF/ED100

SERIE
QUEEN 9

SCHEMA DI INSTALLAZIONE - INSTALLATION DIAGRAM - INSTALLATIONSPLAN - SCHÉMA D'INSTALLATION - ESQUEMA DE INSTALACION - INSTALLATIESCHEMA - IINSTALLATIONSRTNINGAR

MISURE IN mm - DIMENSIONS IN mm - ABMESSUNGEN IN mm
MESURES EN mm - MEDIDAS EN mm - MATEN IN mm

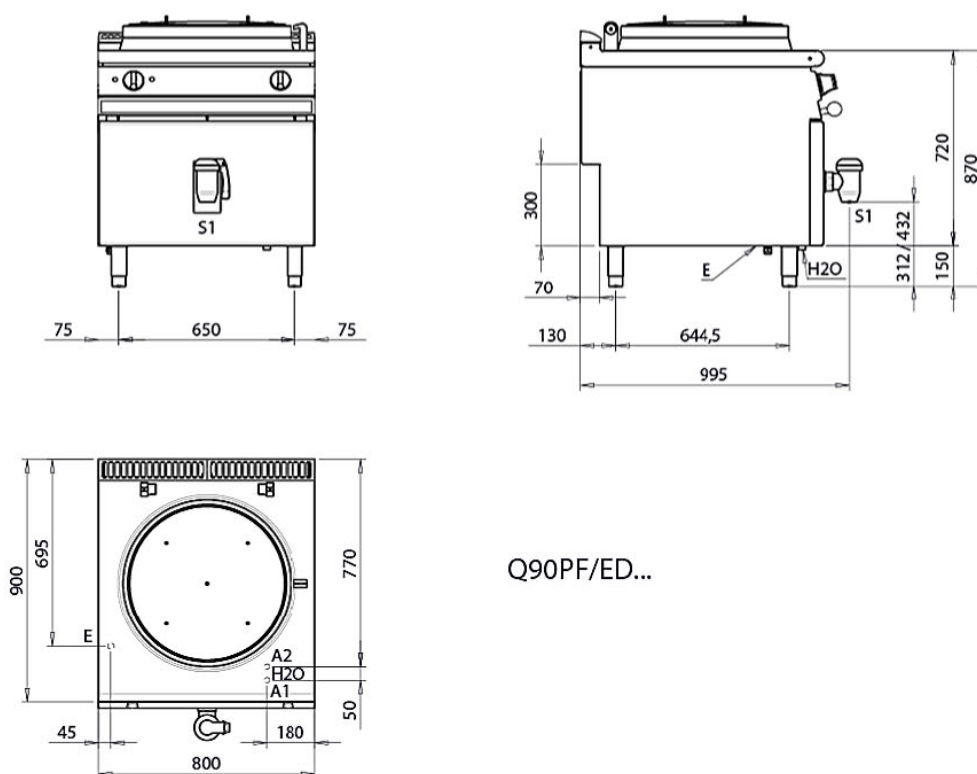

Q90PF/ED...

Legenda - Legende - Key - Légende - Leyenda - Legenda

- H20 Attacchi arrivo acqua - Wasseranschluss - Water inlet - Arrivée eau - Union de agua - Wateraansluiting
- A1 = Calda - Heiss - Warm - Chaude - Caliente - Warm EN ISO 228-1 G 3/4
- A2 = Fredda - Kalt - Cold - Froid - Fria - Koude EN ISO 228-1 G 3/4
- E Pressacavo entrata linea elettrica - Sopfbuchse - Electric cable stress relief
Presse étoupe de câble él. - Elektrische kabelwartel
- S1 Scarico acqua - Wasserablauf - Water outlet - Vidange de l'eau - Desaguadero - Waterafwaansluiting 2'