

DATA SHEET

MINI MARMITE COOK MIX

AMC10A

It heats, whips, mixes and steams, and can be programmed to carry out any type of fast and uniform cooking, automatically, although it can also work at room temperature. Suitable for rottisseries, restaurants, hotels, meat factories, pre-cooked food manufacturers and other collectivities. Designed and manufactured for various uses such as the preparation of croquettes, béchamel, sauce in general, pastry cream, diluting chocolate, jams, syrups, dried fruits, cheese creams, etc.

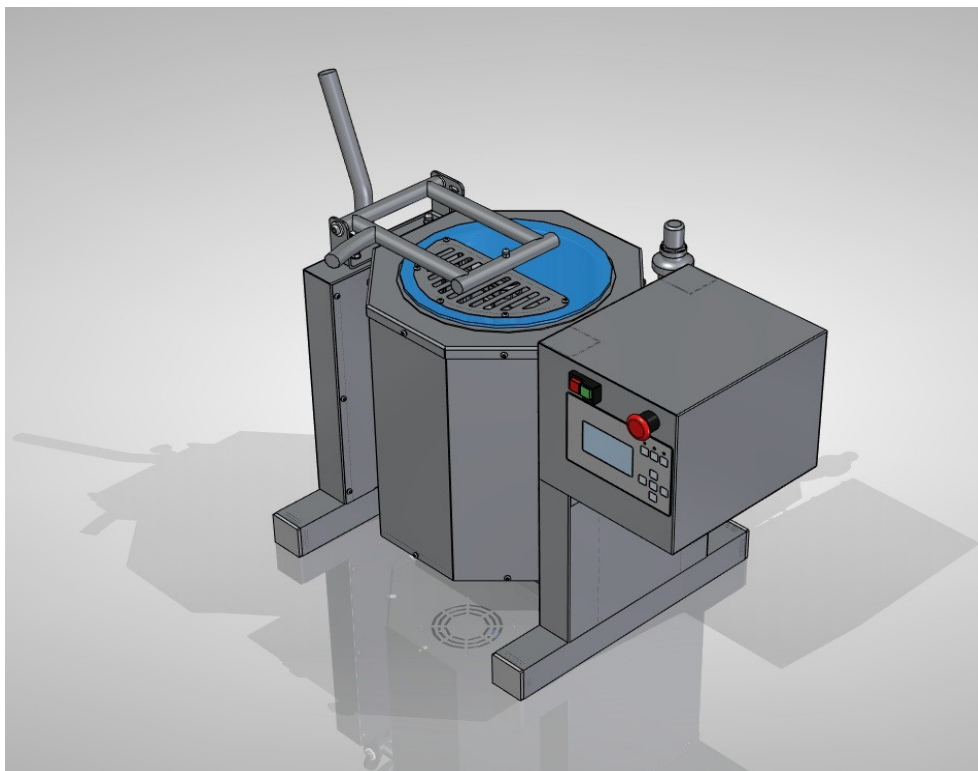

TECHNICAL CHARACTERISTICS:

- **Made of stainless steel.**
- **Double-bodied stainless steel boiler.**
- **Heating by means of stainless steel armoured electric heating elements, immersed in thermal oil.**
- **Remover shovel with Teflon scrapers, preventing the product from sticking to the boiler and removable for cleaning.**
- **Complete control panel consisting of: digital control panel and emergency stop.**
- **Speed variator.**
- **Built according to CE regulations.**
- **Three working positions: continuous rotation in the same direction, rotation with pause, rotation in reverse direction.**
- **Maximum temperature up to 160°C.**

MODEL: AMC10A

DIMENSIONS: LENGTH 900 mm / WIDTH 500 mm / HEIGHT 800 mm.

POWER RESISTANCES: 3 KW.

MOTOR POWER: 0,37 KW.

CAPACITY: 10 L.

VOLTAGE: 230V III.

DIMENSIONS

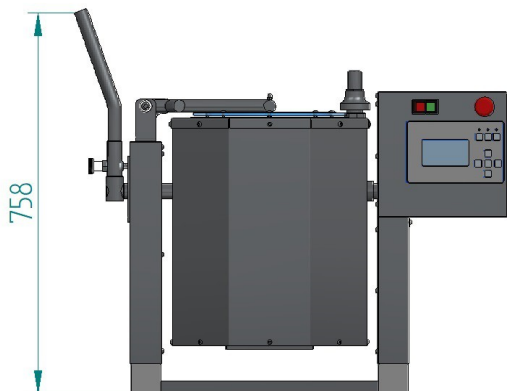

ELEVATED VIEW

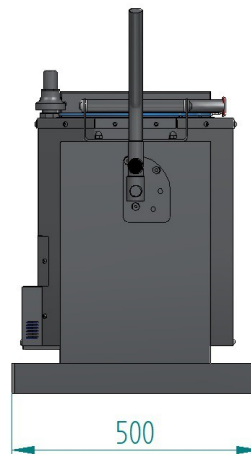

SIDE VIEW

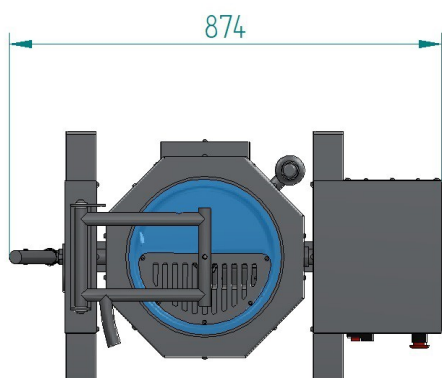

FLOOR VIEW

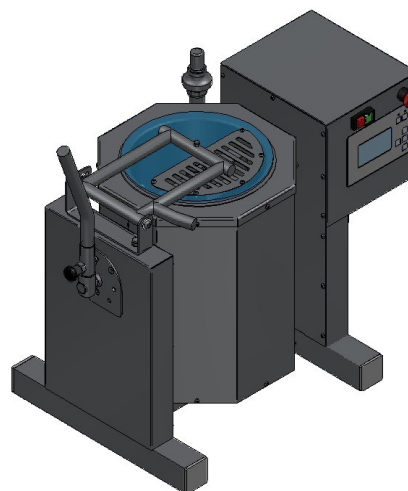

ISOMETRIC VIEW

APPROXIMATE WEIGHT: 59Kg.
ELECTRICAL CONNECTION: 240, 3N, 50/60

The Company reserves the right to make technical modifications without prior notice.

www.inhospans.com

Ø RECIPIENT: 280mm.
DEPTH OF THE RECIPIENT: 288mm.
MAXIMUM CAPACITY: 12,5L.
WATER BOILING TIME: 15-20min.

V1,0 - 2021/02/03