



UVC-8 flood lamp

Description

Capacity: 25 600 eggs/hour

Replaces: n/a

Power supply: 3 kW 400 V 3/N/PE 50/60 Hz
3 kW 230 V 3/N/PE 50/60 Hz

Dimensions: 2147x1254x1583 mm

Minimal workspace: 2000x2500 mm

Compressed air: n/a

Weight: 300 kg

Water: n/a

Operated by: 4 persons

Drain: n/a

Compatibility: VEL-30, MT-8, RZ-8,
UDTJ-500

The disinfectant emits UV-C light with the cumulative power of 950 Watts, which acts on the eggshells and disinfects them by killing 100% of bacteria, including Salmonella. The machine is made out of stainless steel EN 1.4301 (AISI 304).



UVC-1 / UVC-3

MINIMAL WORKSPACE



UVC-6 / UVC-8

MINIMAL WORKSPACE



OVO-TECH HQ
Boczna 43
27-200 Starachowice
Poland, European Union

OVO-TECH USA
1680 Michigan Avenue, Suite 700
Miami Beach, FL 33139
United States

Sales
Email: sales@egg-breakers.com
Tel (Int'l): +48 792 333 900
Tel (US): +1 305 777 2227

Social media

DATE	20.01.2021	AUTHOR	ML
PROJECT	DOK-LAY-ENU.1.1		

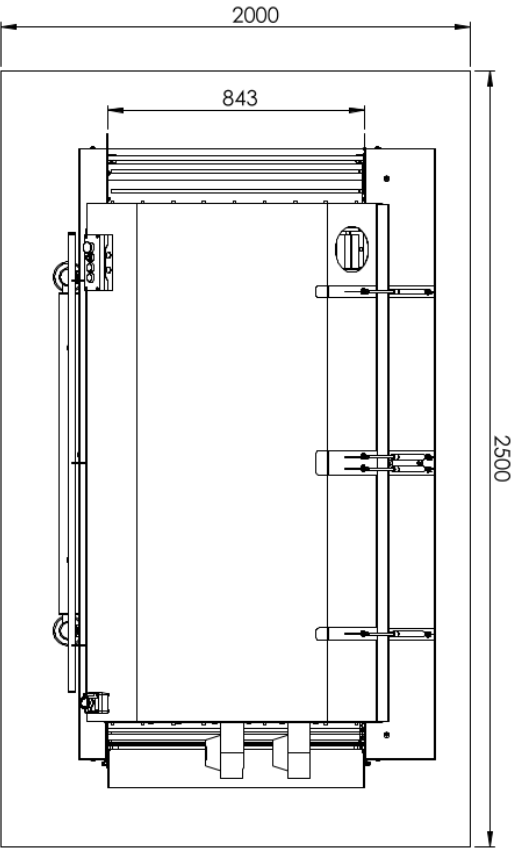
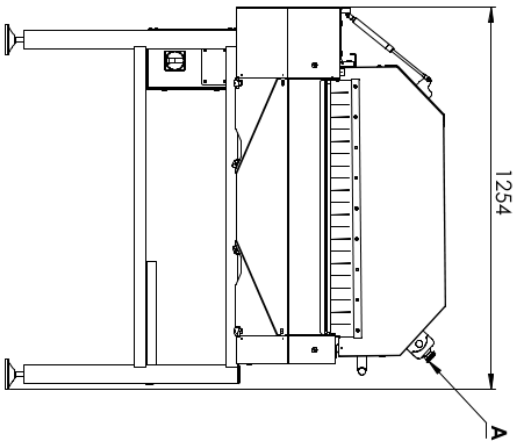
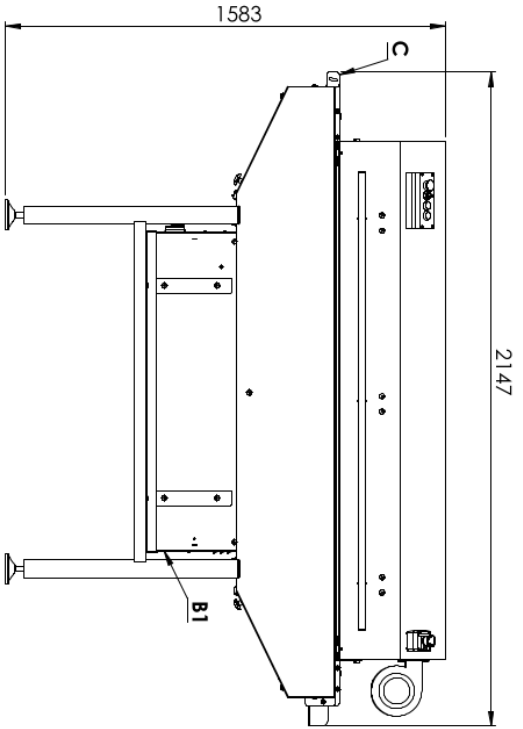

UVC-8 flood lamp

Typical workplaces:	egg breaking facilities, bakeries, confectioneries, pasta making, companies
Capacity:	25000 eggs/hour
Power supply:	3 kW 400 V 3N/PE 50/60 Hz 3 kW 230 V 1N/PE 50/60 Hz
Water connection:	N/A
Compressed air connection:	N/A
Minimal workspace:	2000 x 2500 mm
Dimensions:	2147 x 1254 x 1583 mm
Operated by:	4 persons
Minimal wall clearance:	the rear side - 600 mm
Additional information	N/A
A	control panel
B1/B2/B3	connection: electrical/water/air
C	eggs input
D	eggs/whites outlet
E	egg yolks outlet
F	egg white outlet
G	egg white outlet

OVO TECH

EGG PROCESSING MACHINES

All rights reserved
 The design and development of this machine is the sole property of OVO-TECH.
 Any use of this product, including reproduction, is strictly prohibited without O's written permission & strictly prohibited.