



Project: _____
 Location: _____
 Item #: _____
 Quantity: _____

GENIUS^{MT} 10-11 Gas (boilerless)



MT Technology Genuine MultiTouch display with ultrafast response and high resolution. Intuitive and precise operating by means of sliding, swiping or scrolling.

Quick Set Puts all settings in the exact position with your fingertip. Changes or adds temperature and time settings without interrupting the current cooking process on the display.

4 Unique Start Screens manual, climatic^{MT} favourit, program list

9 Menu Groups: Pasta, Desert/cakes, Bread/rolls, Poultry, Meat, Fish/seafood, Vegetables, Side dishes, Banqueting/Rethermalization

9 Modes of Operation: Vario-Steaming, Steaming, Forced Steaming, Combi-Steam Cooking, Convection, LT-cooking (cook & hold), Delta-T Cooking, Baking

Program capacity: An integrated 9 Menu group display including a library with up to 400 recipes with 20 steps each and product pictures.

Favorite Customized listing for fully automatic programs.

Images Saves individual product images.

Last 20 Function display allows selection of the 20 most recently used cooking processes including manual and programmed settings for immediate restart.

Multi Cooking automatically selects programs with the same cooking method and displays up to 15 timers interchangeably and simultaneously on screen.

Climate Control Patented Climatic^{MT} controls temperature and moisture level. Active humidification and/or de-humidification. Dry heat and humidity in combination with temperature and humidity graphically displayed.

Climatic^{MT} simultaneous setting of temperature and humidity to the exact degree and percentage.

Quick Mode An operating concept especially adapted to the needs of a multi unit operator. It allows using only set recipes and no manual change.

Steam Generation On demand steam generation via Live-Steam-System in the cooking chamber. Manual steam injection at any time. No pre-heating or stand-by required. Significant energy and water savings.

Steam Extraction Steam extracted via patented Steam Protection System (SPS[®]) before program ends. Reduces danger of steam burns. Reduces excess humidity in the kitchen environment. Recirculation system reuses steam for maximum energy efficiency.

Heat Exchanger Heat recovery through Multi-Eco System. Pre-heats incoming water for on-demand steam generation. Highly water and energy efficient. Exceeds drain temperature standards for most municipalities.

Active Temp Automatic pre-heating or cool down of the cooking chamber. Closed door cool-down using residual heat via Multi-Eco System.

Cook and Hold Slow cooking from 86°F to 248°F.

Core Temperature Probe Integral multi-point, thermocouple controlled food core temperature probe. Temperature range 68°F to 212°F. Correction alarm if improperly placed in product.

Fan Auto-reversing fan allowing for 2 distinct fan speeds

Cooking Cabinet Seamlessly welded, coved-cornered stainless steel. Large chamber for greater capacity. NSF conforming, hygienic cooking chamber.

HACCP Automatically records of all relevant HACCP data. On demand access to HACCP information, via integrated screen. USB interface for data exchange with printer or pc.

Multi Connect Easy administration of multiple units with ProConnect^{MT} software and advanced communication interfaces such as LAN or USB.

autoclean^{MT} Patented fully-automatic technology. 100% process-controlled for guaranteed hygiene. Reduced consumption of water and rinsing agents - quick clean in 15 minutes. Color-coded indicator of care product shows remaining quantities. No manual cool-down required. No direct employee contact with cleaning agents. Biodegradable cleaning/rinsing agents. Delayed start time possible.

Spray hose Integrated spray hose with automatic rewind.

Heating Low-pollution gas burner, induction mixture in pre-combustion chamber, high efficiency triple pipe heat exchanger

Description

The unit is a boilerless, self-cleaning, combi oven designed for steaming and convection cooking either separately, sequentially or combined. The combi oven has live-steam-system that generates steam directly into the cooking chamber, for faster heating and reheating without requiring a stand-by mode. An award winning Multi-Eco system simultaneously pre-heats incoming water and cools outgoing condensate to reduce energy and water consumption. The oven fits 10 full size sheet pans or 10 steam table pans.



Eloma North America 3765 Champion Blvd. Winston Salem NC 27105 / USA
 Phone: 800-551-8795 Fax: 336-661-9546 sales@elomausa.com www.elomausa.com

GENIUS^{MT} 10-11 Gas (boilerless)

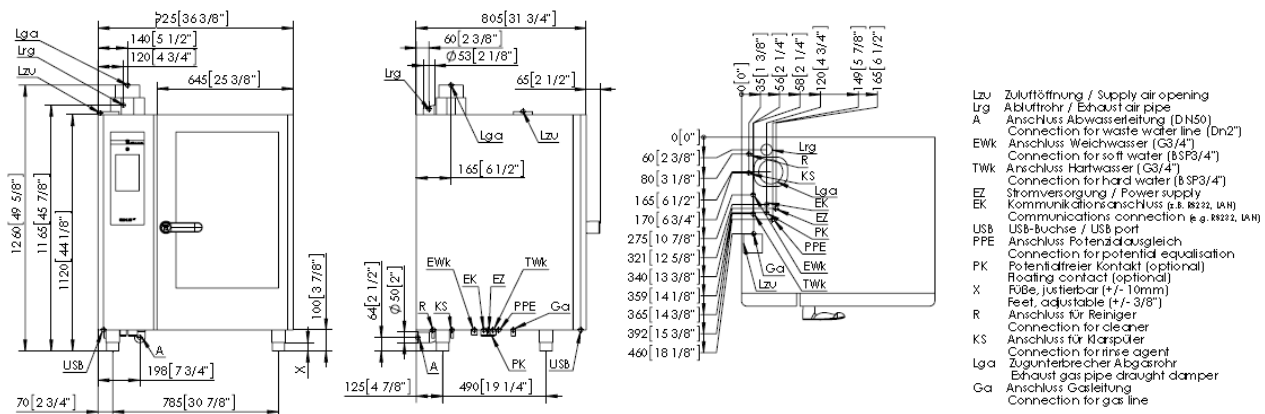

Electrical: Standard	
Voltage:	120 VAC
Phases:	1 phase
Amperage:	15 amps
Connected load:	1 kW
Hz:	50/60
External Dimension:	
Width:	36.42
Depth:	31.69
Height:	44.09
Gross Weight:	390 lbs
Freight Weight:	425 lbs
Water Connection:	
Water Inlet:	Two ¾" garden hose
Drain:	2 inch
Certifications:	ETL, ETL-Sanitation
Protection (water tight):	IPX5

Gas: Standard	
Connected Gas load:	61000 BTU/h
Gas connection:	1/2"
Internal Dimension:	
Number of shelf levels:	10
Distance/Levels:	2,64
Capacity sheet pans (18x26)	10
Capacity steam pans (12x20)	10
Water Quality:	
total hardness:	max. 3° dh
pH- value:	7,0 to 8,5
Water pressure: min/max	30/87PSI

Construction

Constructed to withstand temperature range from 86°F to 572°F and humidification from 0% to 100%. Hygienic cooking chamber with coved corners, seamless welding. Interior and exterior housing of chrome nickel steel CrNi 18 10, BS 304 S15, AISI 304. Tempered door glass (with hinged double panes for easy cleaning) with lock-in-place positions, ventilated door, removable door gaskets & integrated drain pan. Quick release safety door lock for single-handed operation. Automatic fan stop when door opens. Integrated, external hand shower, with automatic return and shut off. Bright interior lighting with halogen lamps. Exhaust and odor seal integrated in drain - fixed connection in accordance with national and international regulations. Sensor-controlled, two-stage cool down water condensation. Split water connections for hard and soft water. Swivelling control panel - easy service access from the front. Manufactured according to quality management system EN ISO 9001. IPX 5 Water-tight rating.

Options

Banquet systems
 Blast Chiller compatible Blast Chiller available... call factory
 Support stands
 ProConnect MT programming software
 Installation kit

Accessories

Hot Spot for Grill marks and Pizza
 FlexiFry for Fry Basket
 PotatoBaker
 Chicken Rack for 8 Chicken
 Cleaner and Rinser Holder wall or table mount

06/2014 Technical amendments reserved

Eloma North America 3765 Champion Blvd. Winston Salem NC 27105 / USA
 Phone: 800-551-8795 Fax: 336-661-9546 sales@elomausa.com www.elomausa.com

GENIUS^{MT} 10-11 Gas (boilerless)

Water requirements

The Incoming water quality should not exceed the following limits.

Eloma water flow rate					
Type		6_11	10_11	12_21	20-21
Softened water	in gal/h	4,00	5,25	6,50	13,25
Hard water	in gal/h	14,50	14,50	14,50	17,00

Water pressure	
min:	30 PSI
max:	87 PSI
Softened water quality	
total hardness:	max. 3° dh 3 grains/gallon
pH- value:	7,0 to 8,5
conductivity:	max. 90 µS/cm ³
CL-:	max. 60 mg/gal
SO ₄ :	max. 100 mg/gal
SiO ₄ :	max. 10 mg/gal
Fe:	max. 0,05 mg/gal
Mn:	max. 0,05 mg/gal
Cu:	max. 0,05 mg/gal
Cl ₂ :	max. 0,10 mg/gal

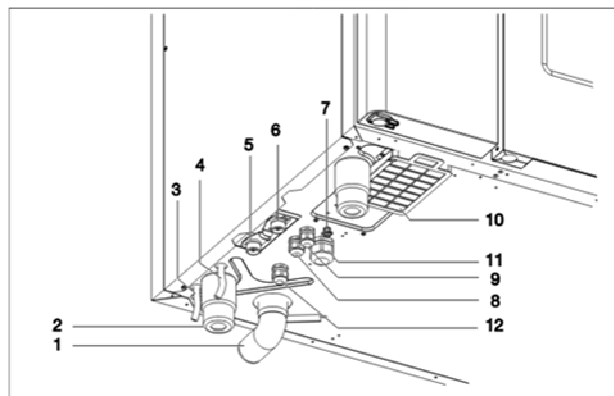

Fig. 2: Connections: size 6-11 or 10-11, electric, right hinged

- 1 Connection for waste water pipe
- 2 Feet, adjustable
- 3 Connection for cleaning agent
- 4 Connection for rinse agent
- 5 Connection for hard water
- 6 Connection for soft water
- 7 Connection for potential equalisation
- 8 Connection for electrical cable
- 9 Communications connection (e.g. RS232, LAN)
- 10 Air filter
- 11 Connection for energy optimiser system (optional)
- 12 Floating contact (optional)